

RESOLUTION No. R-2020-13

**A RESOLUTION AUTHORIZING AND APPROVING THE MAYOR AND/OR CITY CLERK TO ENTER INTO AN AGREEMENT WITH ARISTOTLE UNIFIED COMMUNICATIONS, LLC FOR ANTENNA SPACE, AND FOR OTHER PURPOSES**

**WHEREAS, THE CITY OF WARD** desires to enter into an Agreement (Attachment 1) with Aristotle Unified Communications, LLC (“Aristotle”) to bring Fixed Wireless Technology to the City of Ward; and,

**WHEREAS**, in order to bring this technology to the City of Ward, Aristotle desires to attach – via magnetic footing – necessary equipment to the Ward Water Tower located at 659 Peyton St, Ward, Arkansas; and,

**WHEREAS**, upon entering into this Agreement, Aristotle will provide internet and phone service to the following city facilities as per the Pricing Proposal (Attachment 2:

- Water Treatment Plant
- City Hall
- Fire Stations #1 and #2
- Water Operations Bldg
- Street Department (no charge)
- Animal Shelter (no charge)

**NOW, THEREFORE, IT IS RESOLVED BY THE CITY COUNCIL OF THE CITY OF WARD THAT** the Mayor or City Clerk is hereby authorized to enter into an agreement with Aristotle for Antenna Space and to provide internet and phone service to various city facilities.

Said resolution has been properly introduced and the vote was:

PASSED: YEAS 6 NAYS 0

DATE: May 18th, 2020

APPROVED:

  
\_\_\_\_\_  
Charles Gastineau, Mayor

ATTEST:

  
\_\_\_\_\_  
Courtney Ruble, City Clerk

SEAL

Monthly Summary

Fund	Location	Suddenlink Internet (Monthly Avr)	Centurytell Phone (Monthly Avr)	Aristotle Internet (Monthly)	Aristotle Phone (Monthly)	Difference Per Month
Various	City Hall	\$138.40	\$2,428.46	\$150.00	\$913.20	(\$1,503.66)
Water/Wastewater	WWTP	\$0.00	\$0.00	\$79.99	\$24.20	\$104.19
Water/Wastewater	Shop	\$155.90	\$0.00	\$79.99	\$24.20	(\$51.71)
Fire	Station 1	\$207.91	\$0.00	\$79.99	\$24.20	(\$103.72)
Fire	Station 2	\$0.00	\$72.60	\$79.99	\$24.20	\$31.59
Street	Shop	\$0.00	\$0.00	\$0.00	\$0.00	\$0.00
Animal Shelter	Animal Shelter	\$0.00	\$0.00	\$0.00	\$0.00	\$0.00
<b>Total</b>		<b>\$502.21</b>	<b>\$2,501.06</b>	<b>\$469.96</b>	<b>\$1,010.00</b>	<b>(\$1,523.31)</b>

Annual Summary

\$6,026.52      \$30,012.66      \$5,639.52      \$12,120.00      (\$18,279.66)

Street Shop and  
Animal Shelter  
(monthly)      \$48.40  
Annual      \$1,919.76      \$580.80

**Total Savings of  
Street Shop and  
Animal Shelter**      **\$2,500.56**

# Aristotle Unified Communications

- History of Aristotle, Inc.
- Fixed Wireless Technology
- Ward Internet Proposal



**ARISTOTLE**



## Aristotle Unified Communications

- **Founded in 1995**
  - DSL and Dial-up provider in Little Rock
  - Digital marketing and design team
- **2005: switched to Fixed Wireless Technology**
  - Moved attention to underserved areas in AR
- **AUC also offers digital phone services (VoIP)**

## Fixed Wireless Technology

- Sourced by fiber backhaul
- Line-of-site distribution to locations
- Broadband internet carried between fixed radio links

- Radio towers
- Water towers
- Grain silos

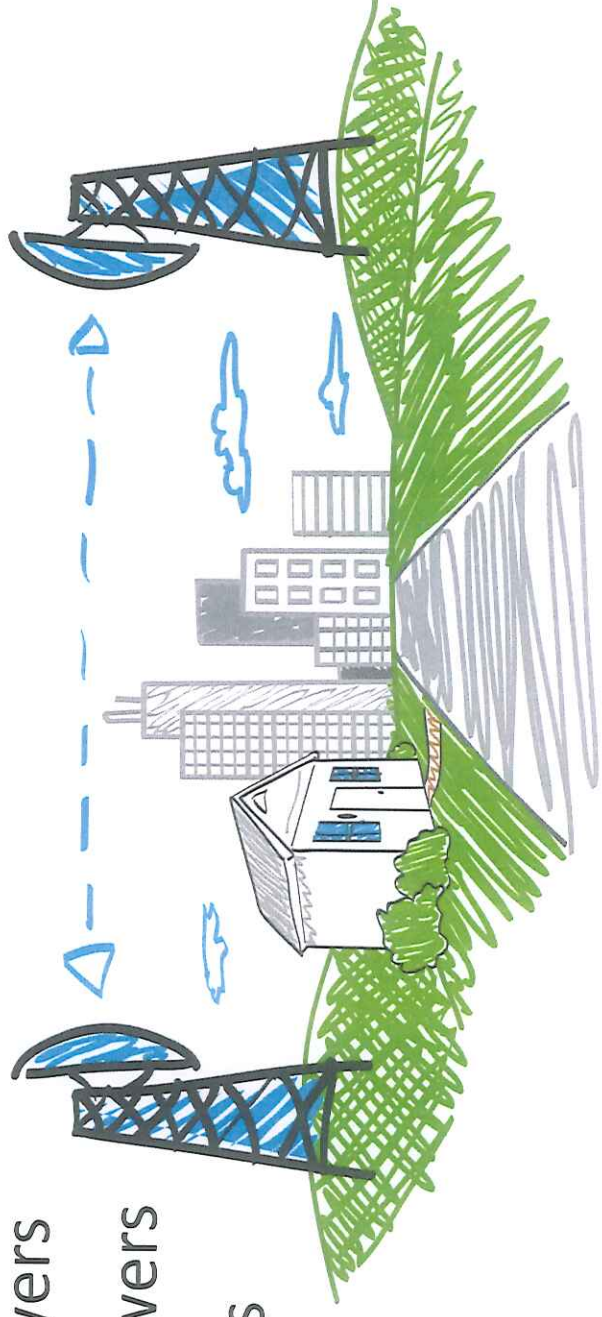

# Fixed Wireless Technology

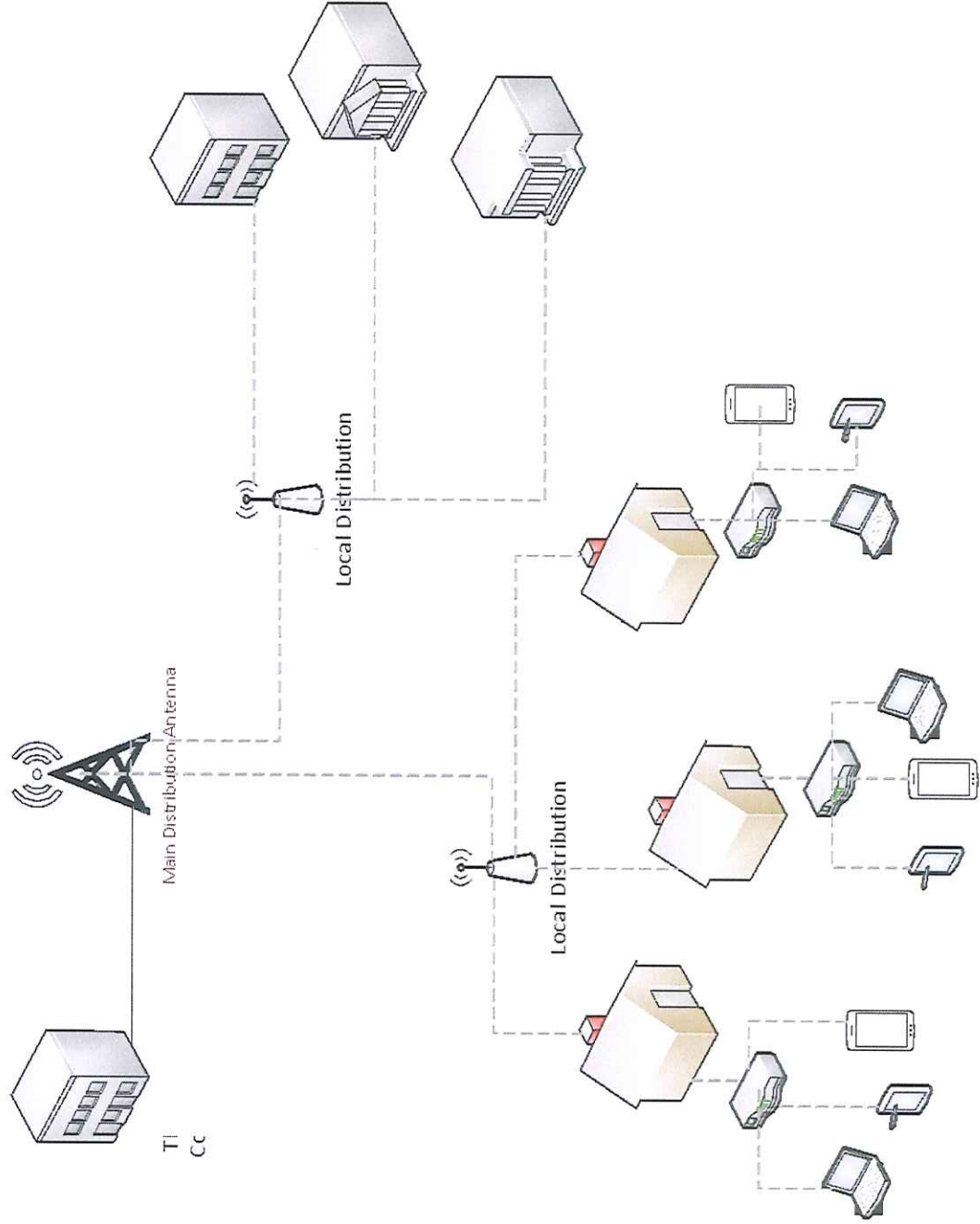

# Fixed Wireless Technology



## Benefits of Fixed Wireless

- Rapid deployment
- Speeds comparable to other fixed carriers
- No data caps or throttling
- Far less expensive than fiber or mobile
- Perfect hybrid solution for a community





## Benefits of Fixed Wireless

- Perfect base for Smart City Deployments
  - Wi-Fi Zone Opportunities
  - Access to City Services
  - Community Engagement

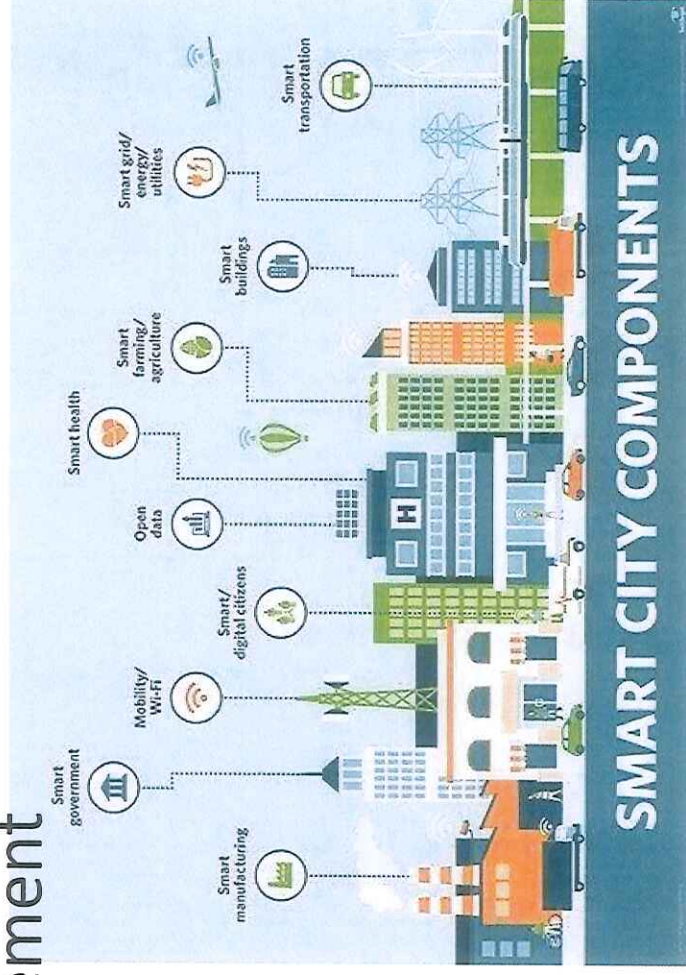

## Opportunities

- AUC hopes to partner with Ward's citizens
  - Provide service to municipal offices 7
  - Able to serve other citizens in Ward
  - Seeking ideas for solutions, sponsorships, and support



## City Internet Proposal

- Internet and phone services to 7 locations
  1. Water Treatment Plant (Highest Priority)
  2. City Office
  3. Fire Station 1
  4. Fire Station 2
  5. Water Operations Building
  6. Street Department
  7. Animal Shelter



ARISTOTLE

## Project Timeline

- Weeks 1-4 (May 22- June 18)
  - Order and Install Equipment on Water Towers
- Weeks 5-6 (June 19-July 3)
  - Install all equipment at customer premises
- July 15, 2020
  - First month's payment charged to the city
- August 15, 2020
  - No more one-time fees; cost drops 28%
- August 15, 2022
  - Phone Equipment paid off; cost drops 15%

Monthly				
Internet	1	\$ 150.00	\$	150.00
Seats	36	\$ 19.95	\$	718.20
Phones	36	\$ 4.25	\$	153.00
Fax Machines	3	\$ 14.00	\$	42.00
One-Time				
Number Port	8	\$ 20.00	\$	160.00
Installation	1	\$ 250.00	\$	250.00
Total				
Month 1			\$	1,473.20
Month 2-24			\$	1,063.20
Month 25+			\$	910.20

# All Other Locations

Monthly					
	Internet	1	\$ 79.99	\$	79.99
	Seats	1	\$ 19.95	\$	19.95
	Phones	1	\$ 4.25	\$	4.25
One-Time					
	Number Porting	1	\$ 20.00	\$	20.00
	Installation	1	\$ 150.00	\$	150.00
Total					
	Month 1			\$	274.19
	Month 2-24			\$	104.19
	Month 25+			\$	99.94

## Free Service Locations

- In exchange for access to two water towers
- Locations with free phone/internet services
  - Animal Shelter
  - Street Department
  - \$5340.00 Value Over Two Years

## Total Cost for AUC Services

	Total	Internet	Phones	Installation
Month 1	\$ 2,295.77	\$ 469.96	\$ 1,010.00	\$ 940.00
Month 2-24	\$ 1,649.96	\$ 469.96	\$ 1,010.00	
Month 25+	\$ 1,414.15	\$ 469.96	\$ 820.05	



## Equipment Highlights

- 3 Different Pieces of Hardware
  - Backhaul Radios (14 lbs)
  - Distribution Radios (1.5 lbs)
  - Customer Premise Equipment (4 lbs)
- Uses less energy than average lightbulb
- Magnetic Mounting Brackets
  - No holes or chipped paint on water towers

## Questions and Contact

**We look forward to working with you!**

### **Rick Hales**

Community Outreach Coordinator

ARISTOTLE | [rhales@aristote.net](mailto:rhales@aristote.net)

[2100 Broadway St. • Little Rock, Arkansas 72206](#)

(P) **501.374.4638** (TF) **800.995.2747** (C) **870.501.9279**

### **Terry Norris**

VP, Operations

ARISTOTLE | [tdnorris@aristote.net](mailto:tdnorris@aristote.net)

[401 West Capitol Avenue – Suite 700 • Little Rock, Arkansas 72201](#)

(P) **501.974.4638** (TF) **800.995.2747** (F) **501.376.1377**



## License For Antenna Space

2100 Broadway St.  
Little Rock, AR 72206  
Phone (501) 374-iNET(4638)  
Fax: (501) 376-1377  
www.aristotle.net

This License for Antenna Space is entered into this TBD day of MO / YR, by and between Aristotle Unified Communications, LLC. ("Licensee") having its normal business operations located at 2100 Broadway St, Little Rock, AR 72206 and City of Ward, Arkansas. ("Licensor").

**Whereas:** At its sole discretion, Aristotle Unified Communications, LLC may determine that the location as identified in the License may be or may have become unsuitable for its intended purpose as provided in this License.

**Whereas:** Aristotle Unified Communications, having determined that the location as herein described no longer meets the needs of Aristotle Unified Communications may void this License at any time prior to the installation of equipment by Aristotle Unified Communications.

**Whereas:** Either party may at its sole discretion, propose an alternative location for consideration by either party without obligation to the other.

**Whereas:** In the event that Aristotle Unified Communications voids this agreement as provided herein, the Licensee will not be liable for payments to the Licensor for non-performance of this Licenses, in part or in whole.

### LICENSE

1. **Term:** The initial term of the License shall be for three (3) years beginning on the effective date, which shall be the first day of the month following the Notice to Proceed to install equipment at the first location operated by the Licensor.
2. **Fees:** Licensee shall pay Licensor, or it's designated Payee, on the first day of each month and each month thereafter during the term of this agreement a license fee in accordance with the attached Addendum #1 – Licenses Fee Schedule.
3. **Reporting:** If requested in writing, Licensee agrees to allow Licensor access to records maintained by Licensee for the purpose of confirming the number of subscribers connecting through equipment on the subject licensed Water Tank located at 659 Peyton St, Ward, Arkansas. Licensor may request a written statement at any time during the term of the License provided such request be limited to one (1) per quarter-year.
4. **Renewal:** After the **initial** term, this License shall automatically renew on the same terms and conditions for three (3) consecutive additional terms of three (3) years each unless Licensee gives to Licensor a sixty (60) days written notice of its intent not to renew prior to the beginning of each term.
5. **Installed Equipment:** Licensee's antenna(s) described in Attachment A shall be mounted on the top of selected structure as described herein.

- A. Licensee agrees to install its fixed wireless equipment within 30 calendar days plus inclement weather days from the date that Licensee notifies Licensor and both parties have agreed upon the Notice to Proceed date.
- B. Licensee may choose to abandon some or all selected locations in accordance with paragraph 9 – Termination, of this agreement.
- C. Licensee may continue operations on one or more structures in accordance with the terms of this agreement regardless of the location or number of abandoned locations.
- D. Licensee agrees to remove all equipment installed by Licensee in the event a location is abandoned.

6. **Installation, Maintenance and Operation of Equipment:**

- A. All labor, equipment, and hardware required to mount Licensee's antenna and any support hardware will be provided and maintained by Licensee at no expense to Licensor.
- B. Power required to operate Licensee's equipment shall be provided by Licensee. However, in the event that a suitable power source is available at the Premises, Licensee may petition Licensor to use the available power source for a nominal monthly fee of \$20.00 per month.
- C. The installation, operation, and maintenance of Licensee's equipment will in no way damage the tower or structure or interfere with other licensed users or the day-to-day operations of the Licensor at the licensed site. If Licensor determines that Licensee has performed work or is in the act of performing work that interferes in the day-to-day operations of Licensor at the licensed site, Licensee shall take steps to modify performed work or modify work in progress to correct any items of work that interferes with the operations of the Licensor.
- D. Licensee will, during the term of the License, and any extension thereto, have the right of ingress and egress to the License Premises for the purpose of maintenance and repair, which shall not be unduly withheld by Licensor; however, such right shall be limited to authorized engineers of Licensee or persons under Licensee's direct supervision. Licensee agrees to abide by the instructions and notification requirements established by the Licensor.
- E. Licensee does hereby covenant to hold and protect Licensor harmless from any and all damage, personal injury or death which shall occur in connection with Licensee's use of the Premises, whether by its authorized engineers or by persons authorized by Licensee.

7. **Non-Interference:** During the term of the License, Licensor will not grant a License to any other party which would directly interfere with Licensee's use of the premises as contemplated herein.

8. **Indemnification:** Licensee does hereby indemnify and hold Licensor harmless from any claim which may arise against Licensor by reason of any occurrence attributable to the installation, operation, or maintenance of Licensee's equipment.

9. **Termination:** Each Party to this Agreement possesses the Right of Terminate of this Agreement in accordance with the terms as set-forth herein.

- A. In the event Licensee determines that the site is or has become unsuitable for the purpose as intended under this License either physically or financially, Licensee may terminate this License upon a thirty (30) day written notice to Licensor.
- B. Any and all fees due and payable to the Licensor by Licensee per Addendum #1 of this Agreement will be paid in full by Licensor within 60-days of the date of Termination.
- C. Upon termination or expiration of the License, Licensee will remove all equipment installed upon the Licensed Premises without causing damage to Licensed Premises or Licensor's property.

- C. Licensor may terminate this agreement upon receipt by Licensee of Licensor's written notice to terminate this Agreement, which shall provide no less than 120 days' notice to termination. Licensee may at its discretion, appeal the Licensor's decision to terminate this agreement, which shall extend the date of termination until Licensee's appeal has been heard by the Ward City Council and a final decision made by the Mayor to enforce the termination of this Agreement.
- D. In the event Licensor can show cause or show justification that a potential exists that the operation of Licensee's equipment endangers the Premises OR water supply associated with the Premises, Licensee agrees to immediately initiate remedies as directed by Licensor and/or cease its operations within the affected area until prescribed remedies may be taken.

10. **Insurance:** Licensee shall provide Licensor with a current Certificate of Insurance naming Licensor as additional insured. The amount of liability insurance shall be no less than one million dollars [\$1,000,000.00] with a two million dollars [\$2,000,000.00] Umbrella policy.

11. **Assignment:** This License may at any time be assigned by Licensee to an affiliate or successor in interest, provided Licensor shall approve use assignment in advance, with such approval not being unreasonably withheld.

12. **Default:** In the event of the failure on the part of Licensee to pay rental in the time and manner hereinabove provided or failure on the part of Licensee of its affiliate to whom Licensee's assignment has been approved by Licensor to perform any other covenant or agreement on its part to be performed hereunder for a period of ninety (90) days shall give the right to Licensor to demand payment immediately using all remedies allowed by the State of Arkansas. Failure by the Licensee to enter into an agreed remedy shall allow Licensor to cancel this license agreement in which event Licensee shall within 90 business days thereafter remove its equipment from Licensor's Premises in such a manner as not to damage said Premises, and Licensor shall further have all other remedies in law or equity against Licensee for any all such damage as it may suffer in connection with such breach on the part of Licensee.

13. Failure on the part of either party to exercise its right to terminate at any time shall not constitute a waiver of that party's right to terminate upon any subsequent breach by the other party or that party's affiliate.

Licensee: Aristotle Unified Communications, LLC <hr/> Address: 2100 Broadway St <hr/> Little Rock, AR 72206 <hr/> By: _____ <hr/> Print Name & Title: Terry D. Norris, COO <hr/> Date: _____ <hr/>	Licensor: _____ <hr/> Address: _____ <hr/> By: _____ <hr/> Print Name & Title: _____ <hr/> Date: _____ <hr/>
---	--

## ADDENDUM #1: LICENSE FEE SCHEDULE

### Fees to be paid to the licensee shall be as follows:

The City of Ward herein grants authority to Aristotle Unified Communications, LLC, the Licensee of this Agreement to Utilize the Premises as herein described for the purpose of providing Internet services to residents of the City of Ward and to provide Fixed Wireless Internet service as "Trade-In-Kind" for the use of the Premises described in this Agreement:

- Free Internet service to a designated facility utilized by the City at no charge to the City inclusive of all normal and usual fees associated with the installation of and on-going maintenance of the receiving radio, antenna, router, wiring and various hardware items that are essential to the function of the installed Fixed Wireless Internet System located on the mutually agreed upon City facility.
- Said "trade-in-kind" having a face value of no less than \$425.00 (labor and materials) plus an additional \$75.00 per month for services.
- In Lieu of trade-in-kind, by mutual agreement, Licensee shall pay to the City of Ward a base fee of \$75.00 per month and a sum of \$1.00 per month per Active Subscriber [a customer in good standing with at least 3-months of consecutive paid service that utilizes the distribution network mounted to the Premises].
  - Licensor may request and receive written reports indicating the customer count, limited to one report per yearly quarter.
  - Licensor may request and be granted access to Licensee's management system to audit the number of Active Subscribers, limited to once every 6-months. Said access will be limited to a designated individual associated with the City Council. Said access to be further limited to the Corporate office of Licensee where the Chief Operating Office or the Chief Financial Officer shall generate said report while designated individual observers and receives a printed report at that time.

Attachment 'A'  
Equipment Schedule

Licensee shall install the following equipment:

BASE CABINET

1. One waterproof cabinet, measuring 36" X24" X 10" or similar, mounted to two vertical pipes on Unistrut rails. Cabinet will house all non-hardened service electronics consisting of but not limited to the following:
  - a. 2 or 4 Gel type 90 amp-hr batteries
  - b. 1 – Tycon TP-BC24-300 Charger / regulator (24VDC power output)
  - c. 1 – Netonix WS-12-250-DC Managed switch
  - d. 1 – Mikrotik Router, CCR1009-7G-1C-1S+PC
  - e. 1 – Baicells base-station
  - f. Misc. surge protectors and circuit breakers
2. From the Base Cabinet to the Water Tank:
  - a. One 2"dia PVC conduit to contain multiple CAT6 cables and one power cable
  - b. One ¾" PVC conduit from cabinet to power source with one, 14-3 power cable

TOWER MOUNTED EQUIPMENT

1. Single 2" dia conduit and a single ¾" conduit run from bottom of Water Tank to tank catwalk where conduit will terminate in 8' sq and 4" sq (respectively) junction box.
  - a. CAT6 cable – a total of 4 to 6 cables will be installed
  - b. Power – stranded 14 ga. In ¾" conduit from cabinet to top of water tank.
2. Wireless Mount: one – FMM-STD, tripod with three magnetic footings with 83" tall mast
3. Wireless Radios mounted to mast
  - a. Two, Baicell sector panels, 27" X 7" X 3.5"
  - b. One backhaul dish, 36" dia
  - c. One PTP dish, 18" dia.



# Presentation to the Ward City Council

Jonathan Duncan, Rick Hales





**From:** kate.reynolds@rfdatacom.com  
**Sent:** June 19, 2019 9:30 PM  
**To:** kate.reynolds@rfdatacom.com  
**Subject:** Magnetic Antenna Mounting - Parabolic, Panels, Omni  
**Attachments:** Magnacurve Top Tank Mount.PDF; Magnacurve SideTank Mount.PDF

## OUTDOOR MAGNETIC ANTENNA MOUNTING

RF Datacom announces the Flexmount, a magnetic antenna mounting solution for water tanks and other steel structures..

- All Antennas - Parabolic, Panels, Sectors, Omni, Yagi.
- Rapid / straightforward installation.
- No more high-altitude welding, draining water tanks or re-painting blistered interiors. No epoxies which degrade over time becoming unstable.
- The Flexmount is built entirely in the USA by Magnacurve, a veteran owned company offering a lifetime warranty.
- Available for Top-of-Tank and Side-of-Tank installation.
- Light-Duty, Standard-Duty, Heavy-Duty, and custom versions are available.

Please contact me for additional info and pricing.

Kate Reynolds  
RF Datacom, Inc.  
[www.rfdatacom.com](http://www.rfdatacom.com)

PATENT PENDING

1

2

3

4

FMM-LITE

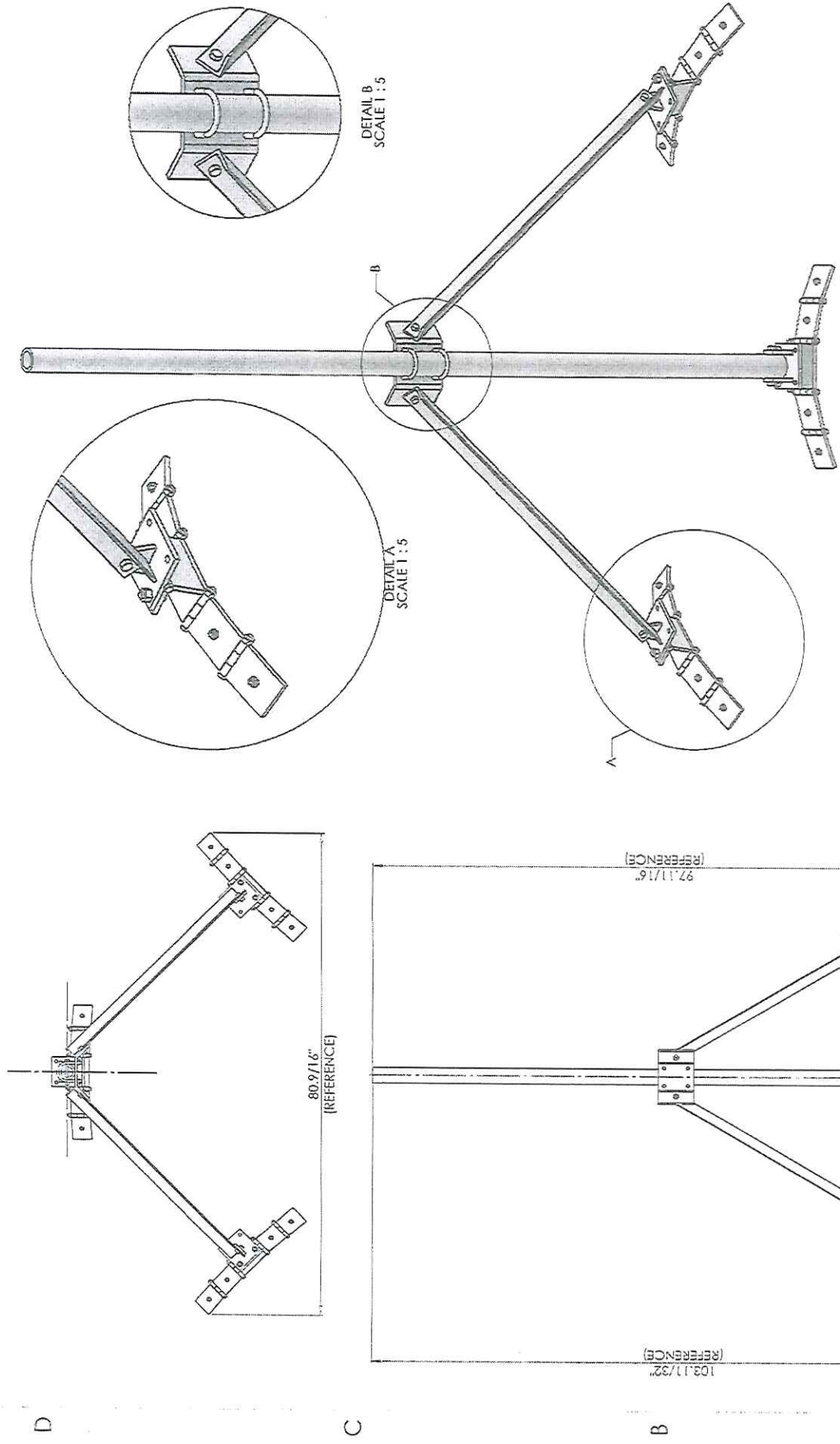

**NOTE:**  
1. PRODUCT CONTAINS EXTREMELY STRONG MAGNETS AND MUST BE HANDLED WITH EXTREME CAUTION TO AVOID BODILY HARM OR MATERIAL DAMAGE.

DESIGNED BY	DATE	MAGNACURVE
DRAWN BY	P. FERRETTI	1997/04
CHECKED BY	J. VARGAS	1997/04
APPROVED BY	J. VARGAS	1997/04
SCALE	1:1	
QUANTITY		
COMPANY		
MATERIALS		
FINISHES		
PACKAGING		
MARKING		
TESTING		
INSPECTION		
REVISIONS		
REV	NO.	
C	0078-16	
SCALE	N/A	WEIGHT
		SHEET 1 OF 3

1

2

3

4

**FMM-HD**

**PATENT PENDING**

1 2 3 4

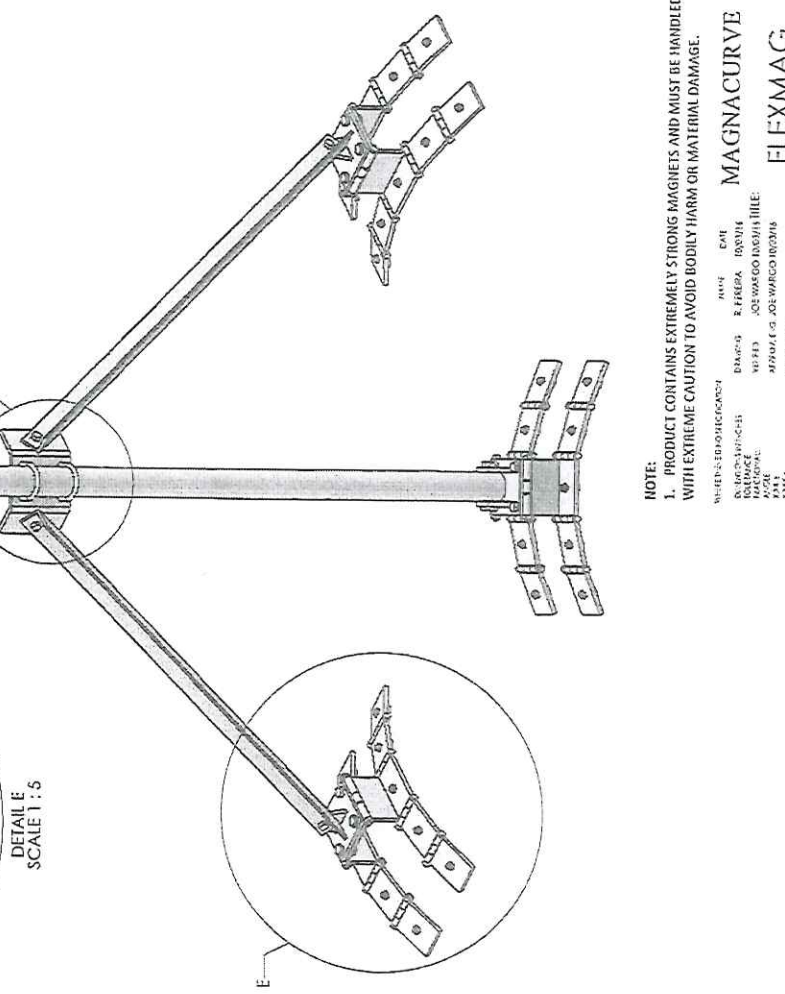
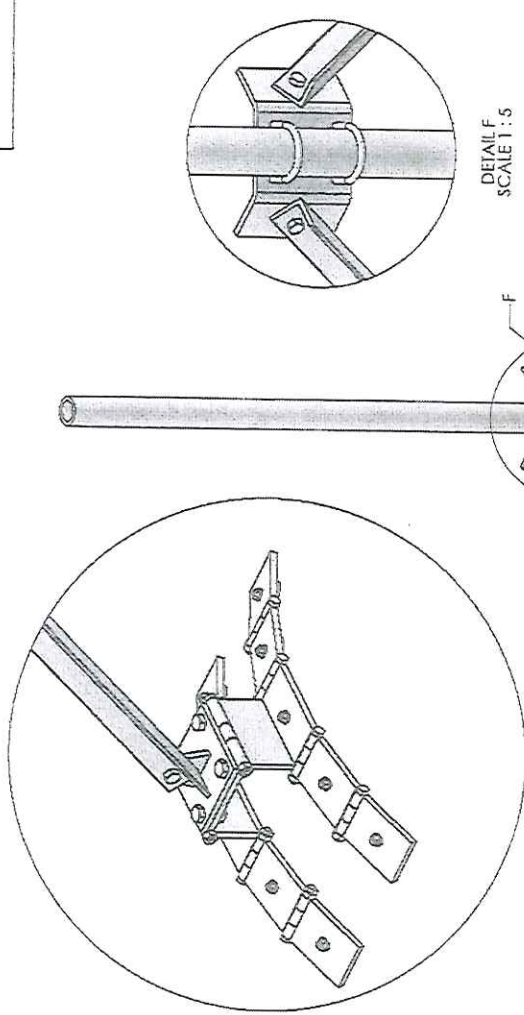
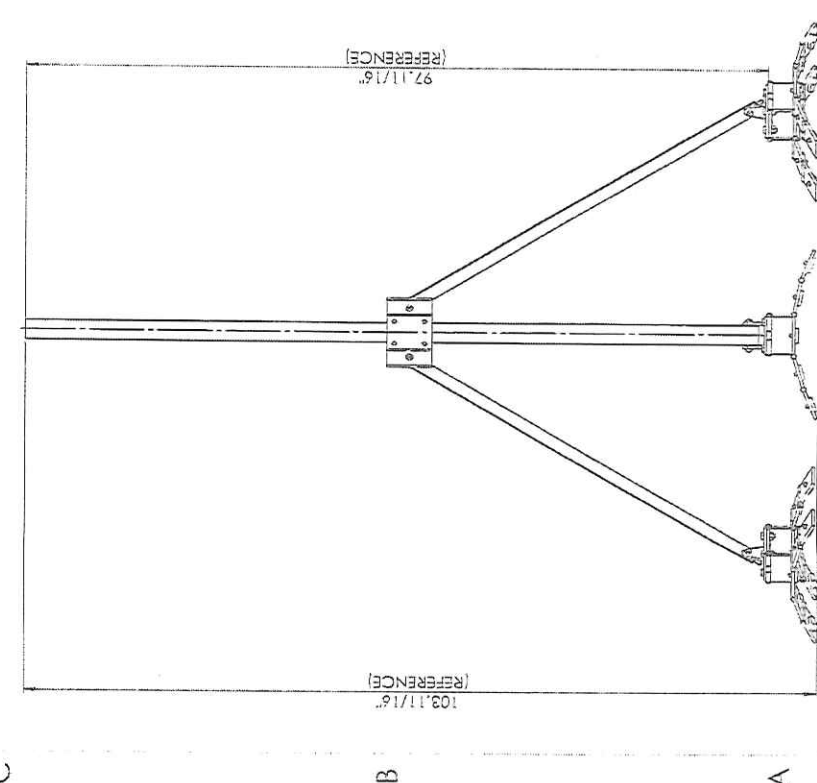
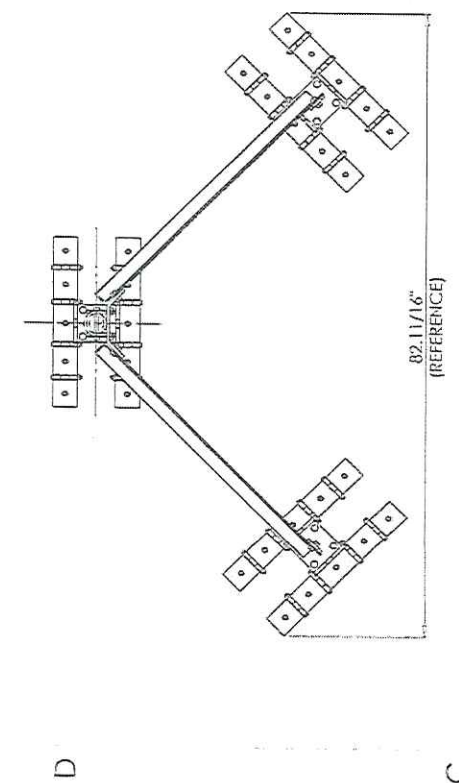

DESIGNER: [unreadable]  
 DRAWN BY: [unreadable]  
 CHECKED BY: [unreadable]  
 DATE: [unreadable]

MATERIAL: GALVANIZED STEEL  
 FINISH: POLYURETHANE POWDER COATING  
 COLOR: BLACK  
 WEIGHT: APPROXIMATELY 1.5 LBS.  
 DIMENSIONS: APPROXIMATELY 103.11/16" H X 82.11/16" W X 1.5" D

**NOTE:**  
 1. PRODUCT CONTAINS EXTREMELY STRONG MAGNETS AND MUST BE HANDLED WITH EXTREME CAUTION TO AVOID BODILY HARM OR MATERIAL DAMAGE.

COMPANY: MAGNACURVE  
 ADDRESS: 10000 W. WASHINGTON AVE.  
 CITY: DENVER, CO 80231  
 PHONE: (303) 751-1111  
 FAX: (303) 751-1112  
 WWW: WWW.MAGNACURVE.COM

SHEET NO. 0078-16  
 REV. C  
 SCALE: N/S WEIGHT: 1.5 LBS.

1 2 3 4



# FMM-W-HD

PATENT PENDING

1

2

3

4

D

C

B

A

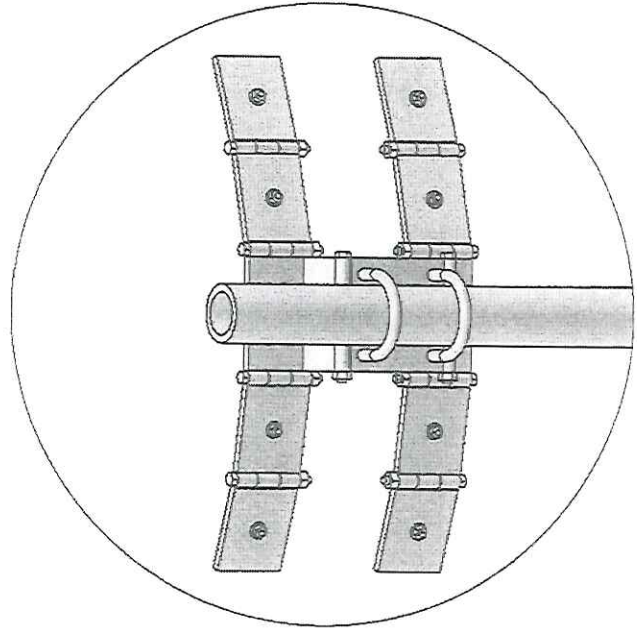
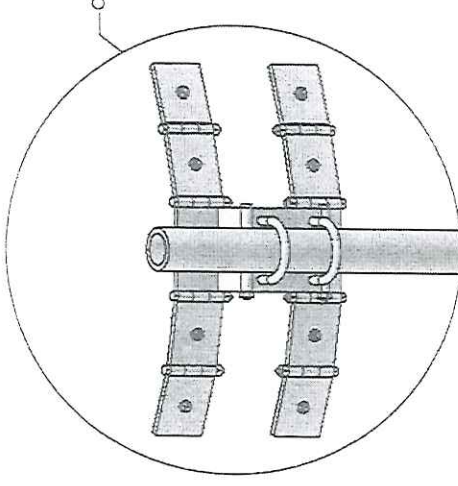
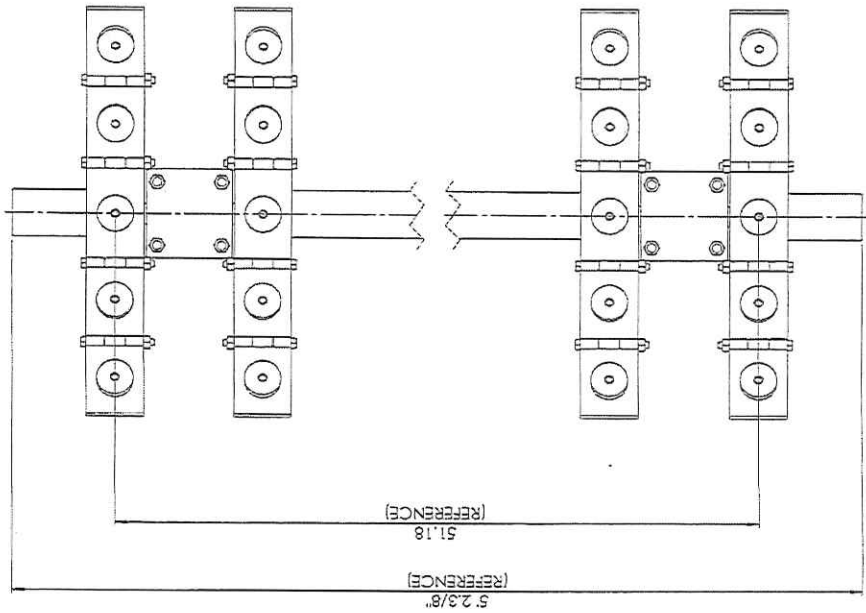
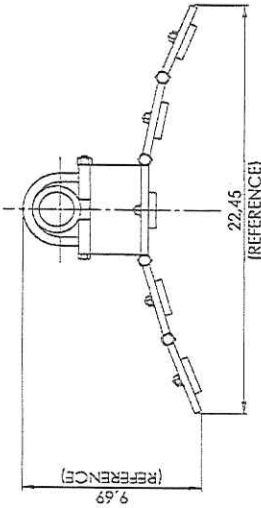

DETAIL C

**NOTE:**  
1. PRODUCT CONTAINS EXTREMELY STRONG MAGNETS AND MUST BE HANDLED WITH EXTREME CAUTION TO AVOID BODILY HARM OR MATERIAL DAMAGE.

DESIGNED BY: MAGNACURVE  
 DRAWN BY: J. PEREZ, INPHIA  
 CHECKED BY: J. PEREZ, INPHIA  
 APPROVED BY: J. PEREZ, INPHIA  
 DATE: 08/16/16  
 SCALE: 1:1

MATERIALS:  
 GALVANIZED STEEL  
 FLEXMAG MOUNT (WALL MOUNT)  
 FLEXMAG MOUNT (WALL MOUNT)  
 FLEXMAG MOUNT (WALL MOUNT)

ADDRESS: 1000 W. 10TH AVE.  
 DENVER, CO 80202  
 PHONE: 303.733.1111  
 FAX: 303.733.1111  
 WWW.MAGNACURVE.COM

SIZE: C  
 DWG. NO.: 0081-16  
 REV: 1

SCALE: 1:1

SHEET 3 OF 3

1

2

3

4

D

C

B

A

